

J58312

Proludic

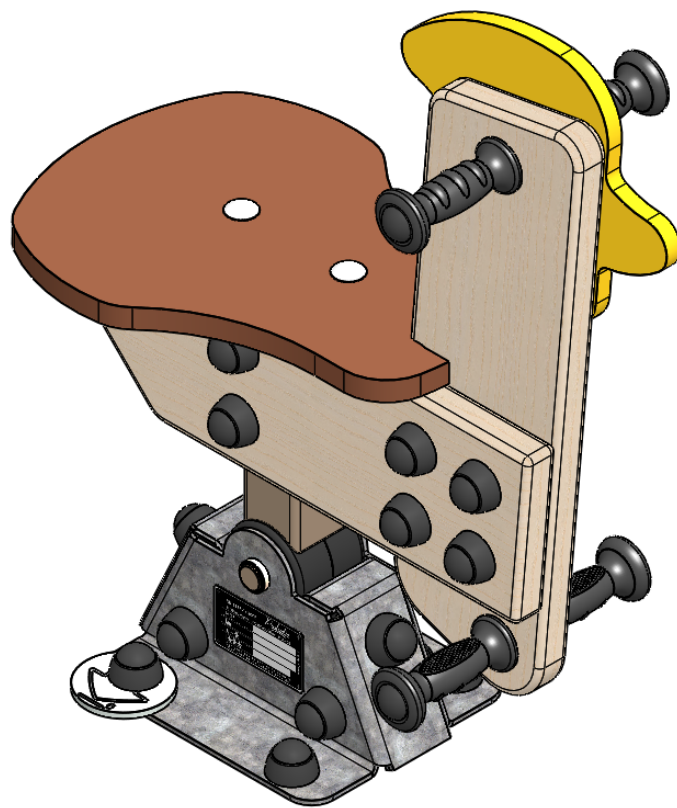

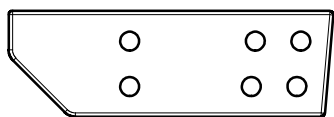

DM58104
1X

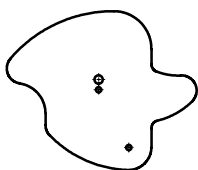

ET58107J
1X

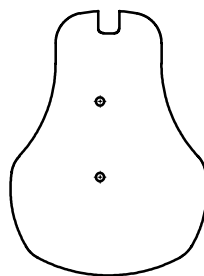

F58113
1X

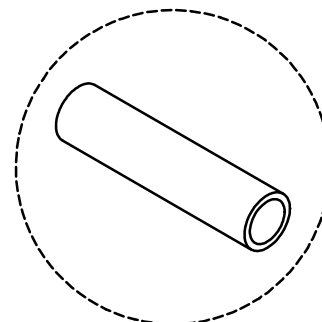

LG58111
2X

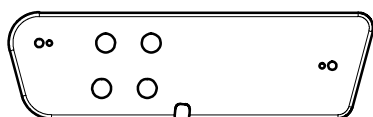

DM58105
1X

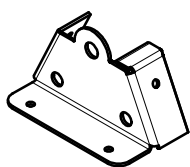

LG58108
2X

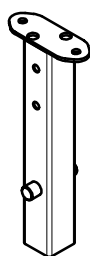

LGP58109
1X

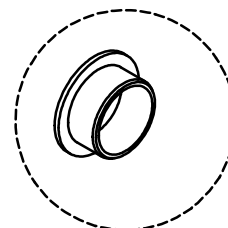

L58112
2X

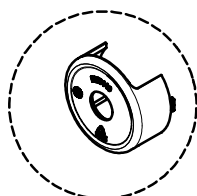

M58110
2X

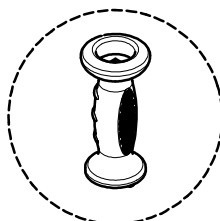

MI820N
4X

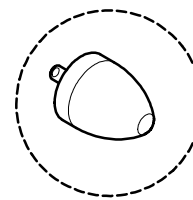

R2504
2X

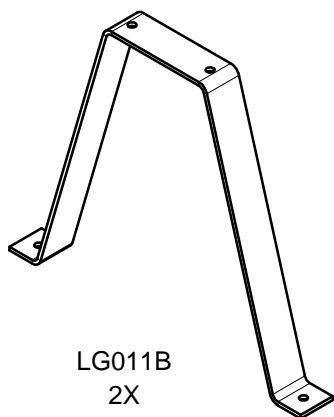

LG011B
2X



EHS58115
1X



LZ220
1X



LZ230
1X

Réf	Qté
LA000	1
M10310N	24
M10440N	28
MI0002	1
MU2614	6
MU3908	4
VBT6x30	1
VEFM10	22
VR10x22	4
VTH10x30	4
VTH10x40	4
VTH10x70	4
VTH10x90	2
VTH10x100	2
VTRCC10x40	2

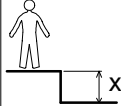
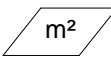

ProLudic

N°		
1	0.6 m	7 m ²

— Zone d'impact
Impact area
Area de impacto
Fallraum
Valzone



Point de référence
Setting out point
Punto de referencia
Bezugspunkt
Referentiepunt

- - - Espace libre
Free space
Espacio libre
Freiraum
Vrije ruimte

EN1176-1:2017
EN1176-6:2017

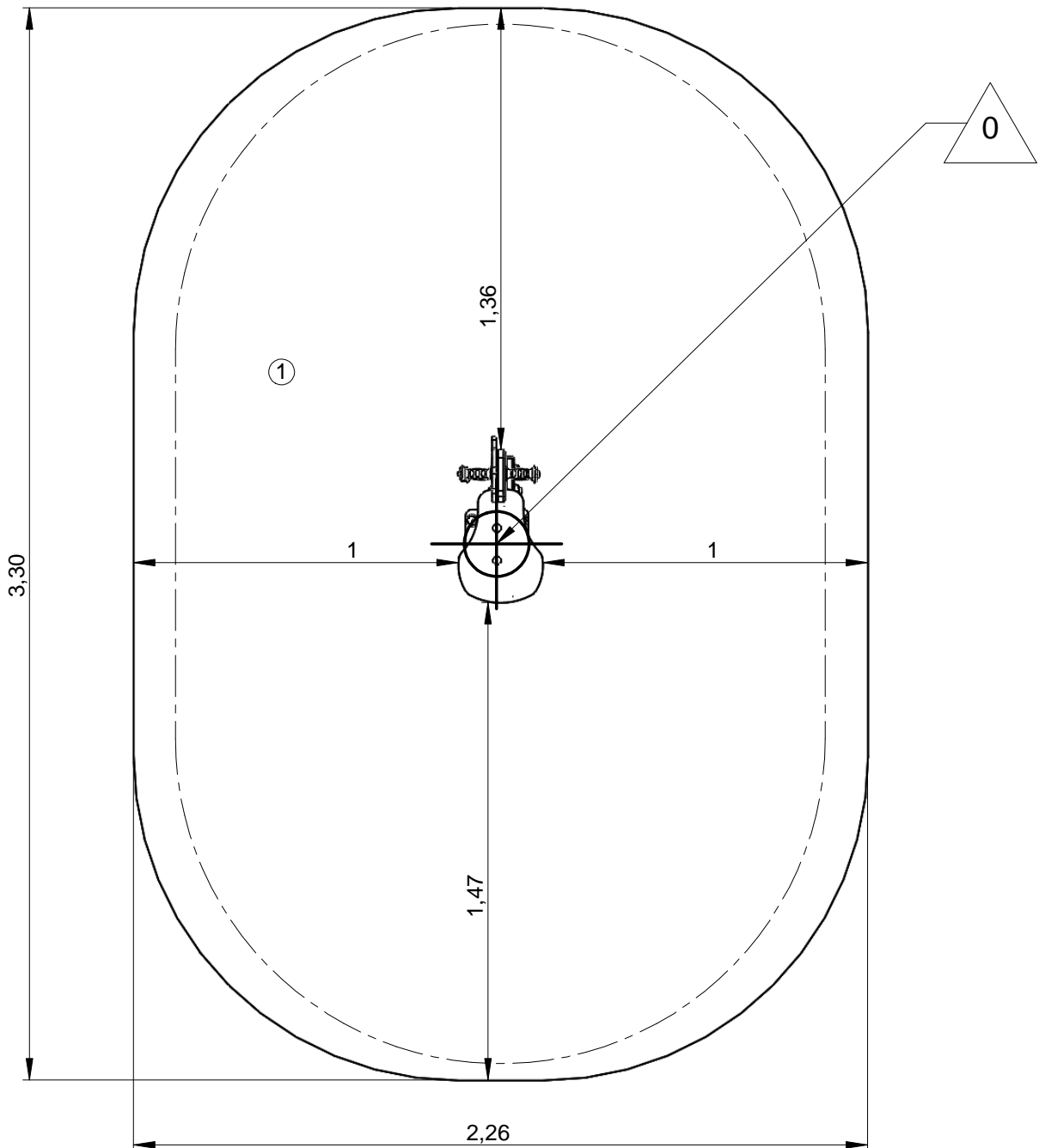

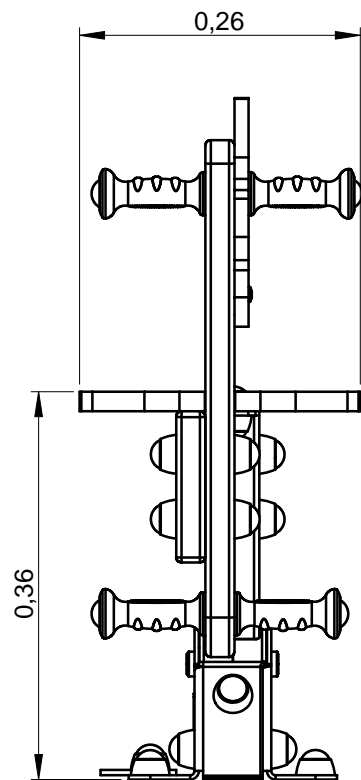
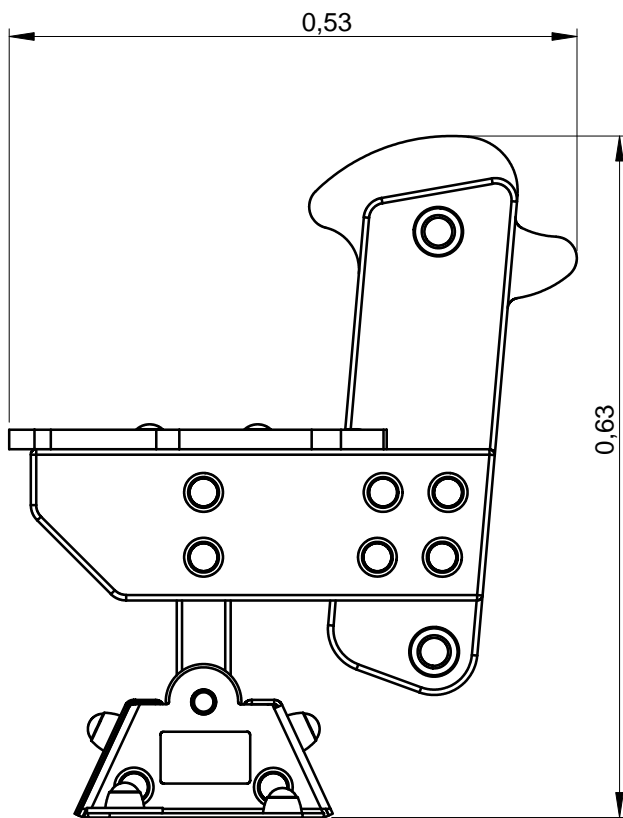
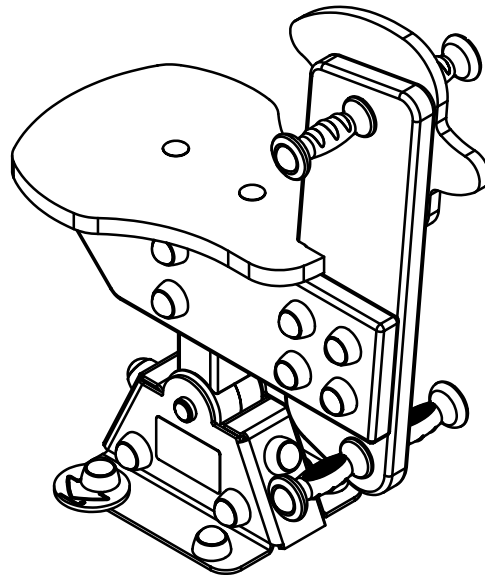

— Zone d'impact
Impact area
Area de impacto
Fallraum
Valzone **7 m²**

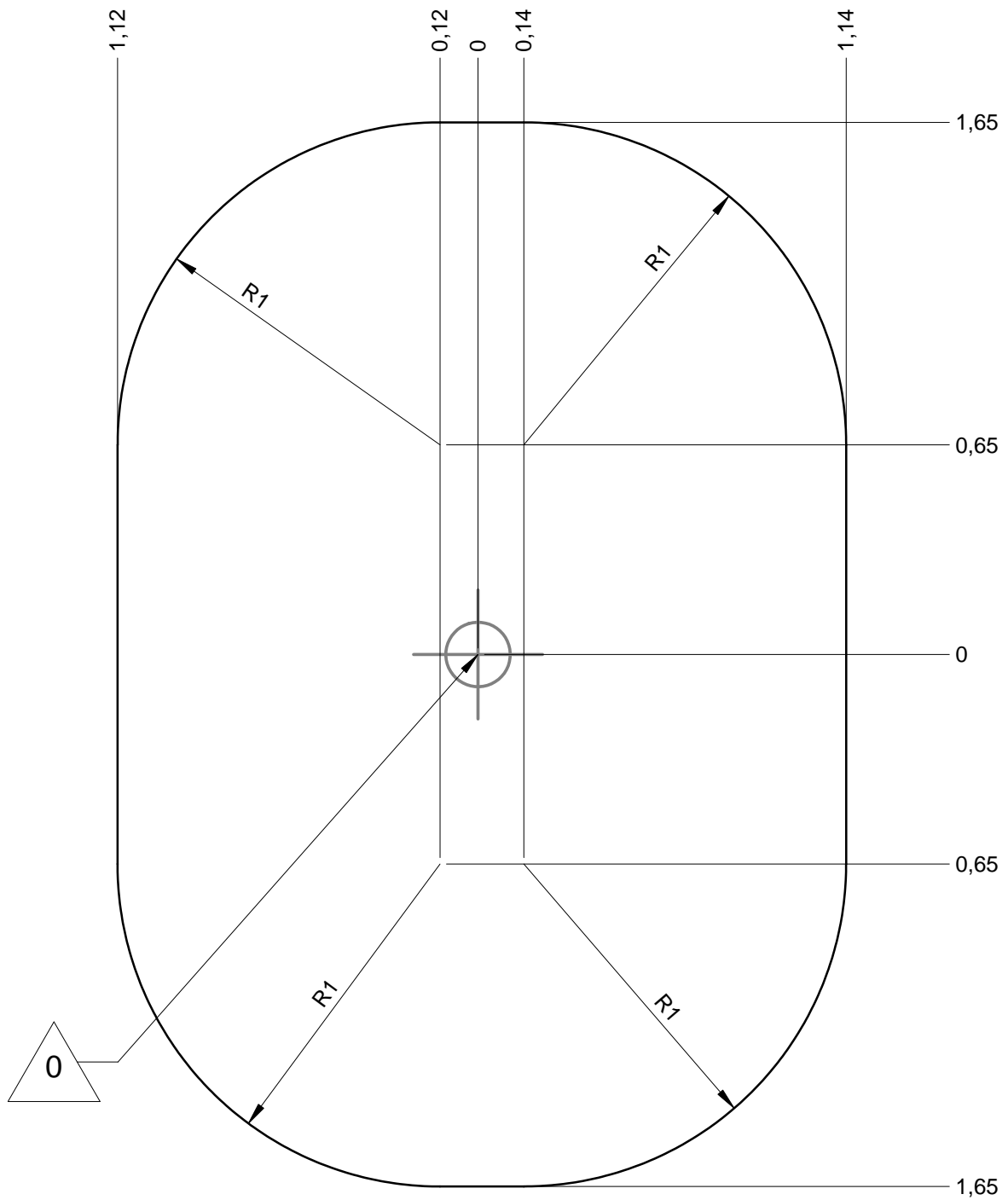

— Sol souple
Wetpour
Caucho continuo
Synthetischer Fallschutz
Gietvloer

7 m²

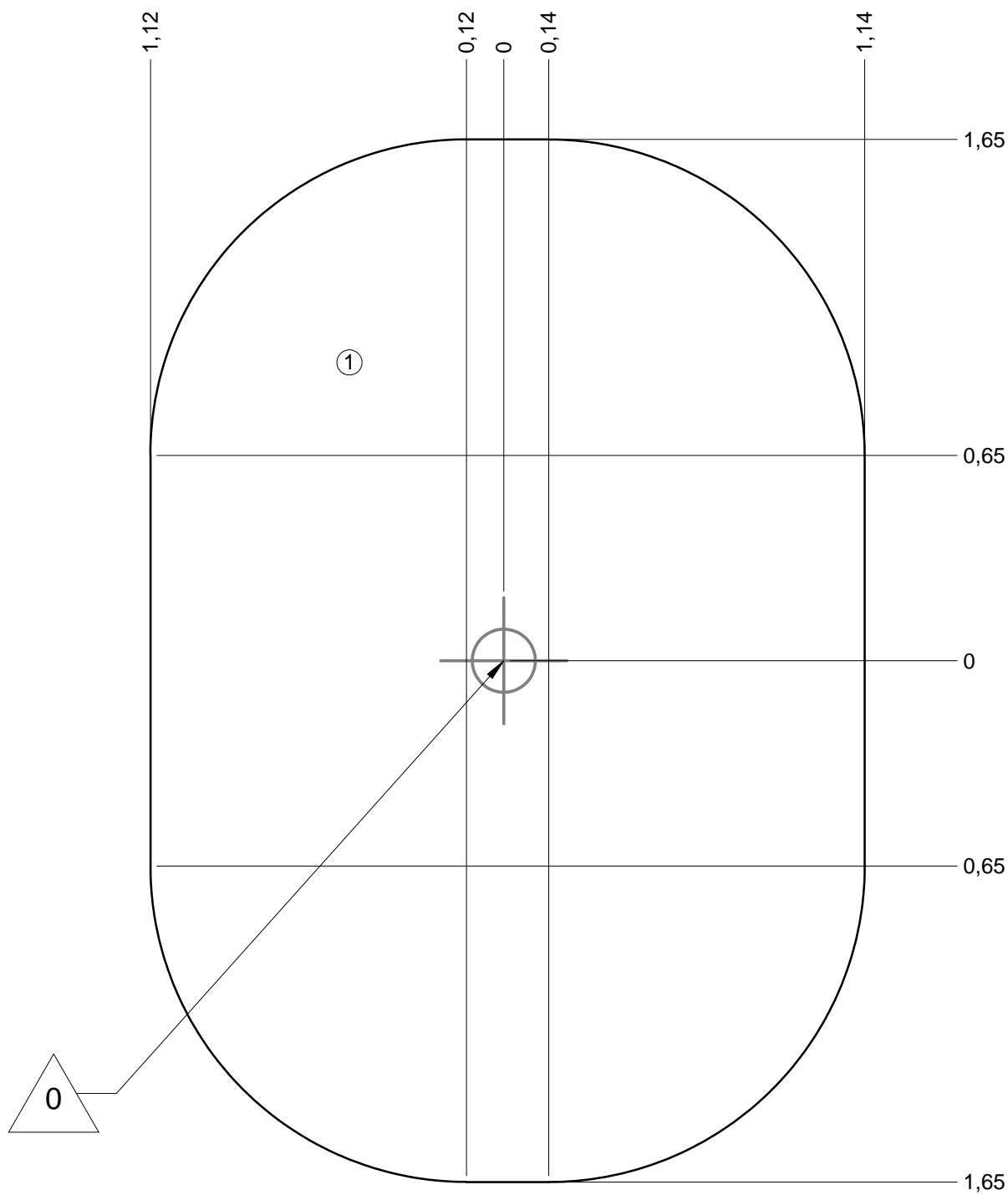

— Dalle béton
Concrete pad
Solera de hormigon
Beton Bodenplatte
Betonnen bodemplaat

12 m
8 m²

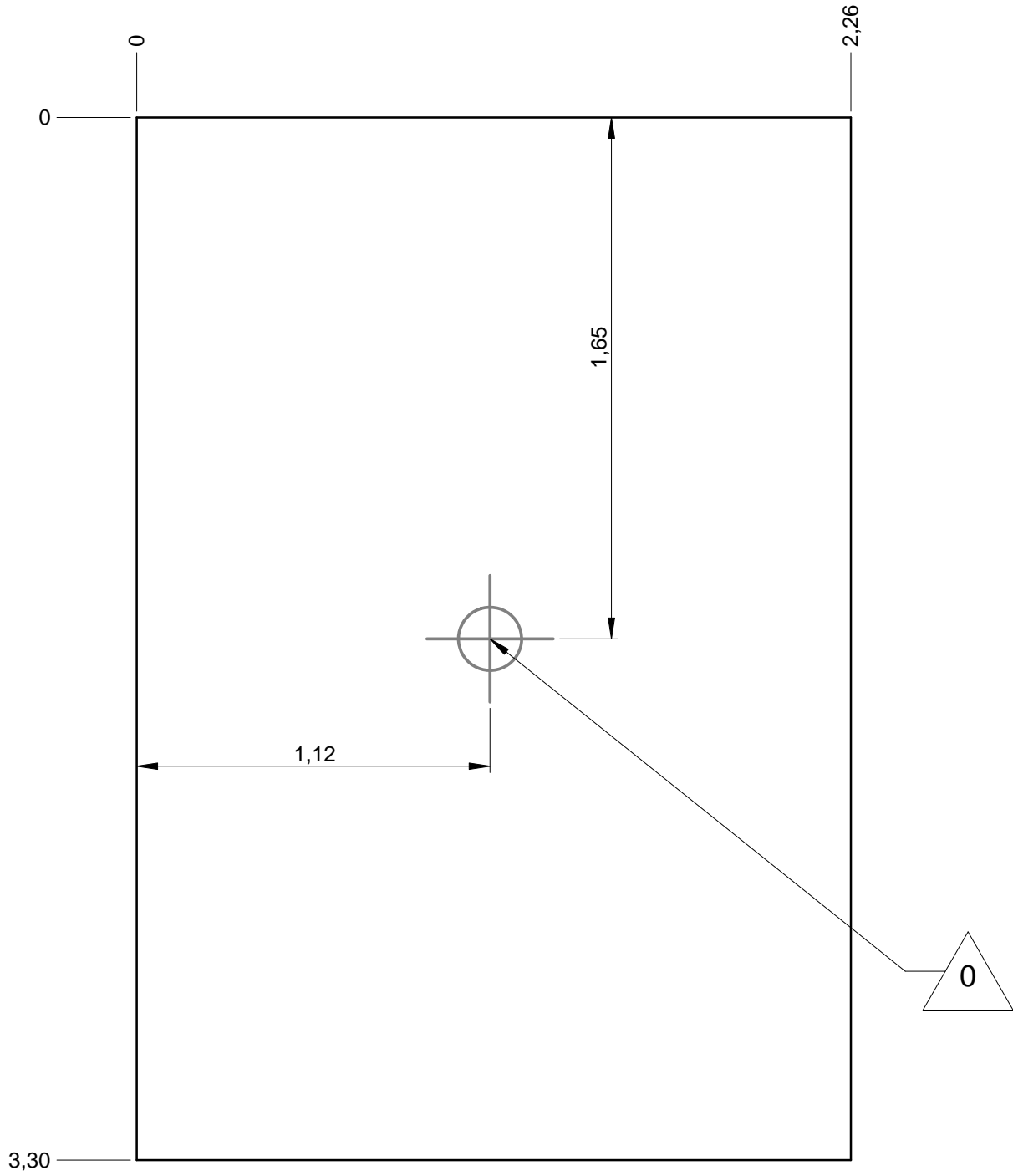

— Sol fluent
Loos partucule material
Arenero
Loses Bodenmaterial
Los bodemmateriaal

12 m
9 m²

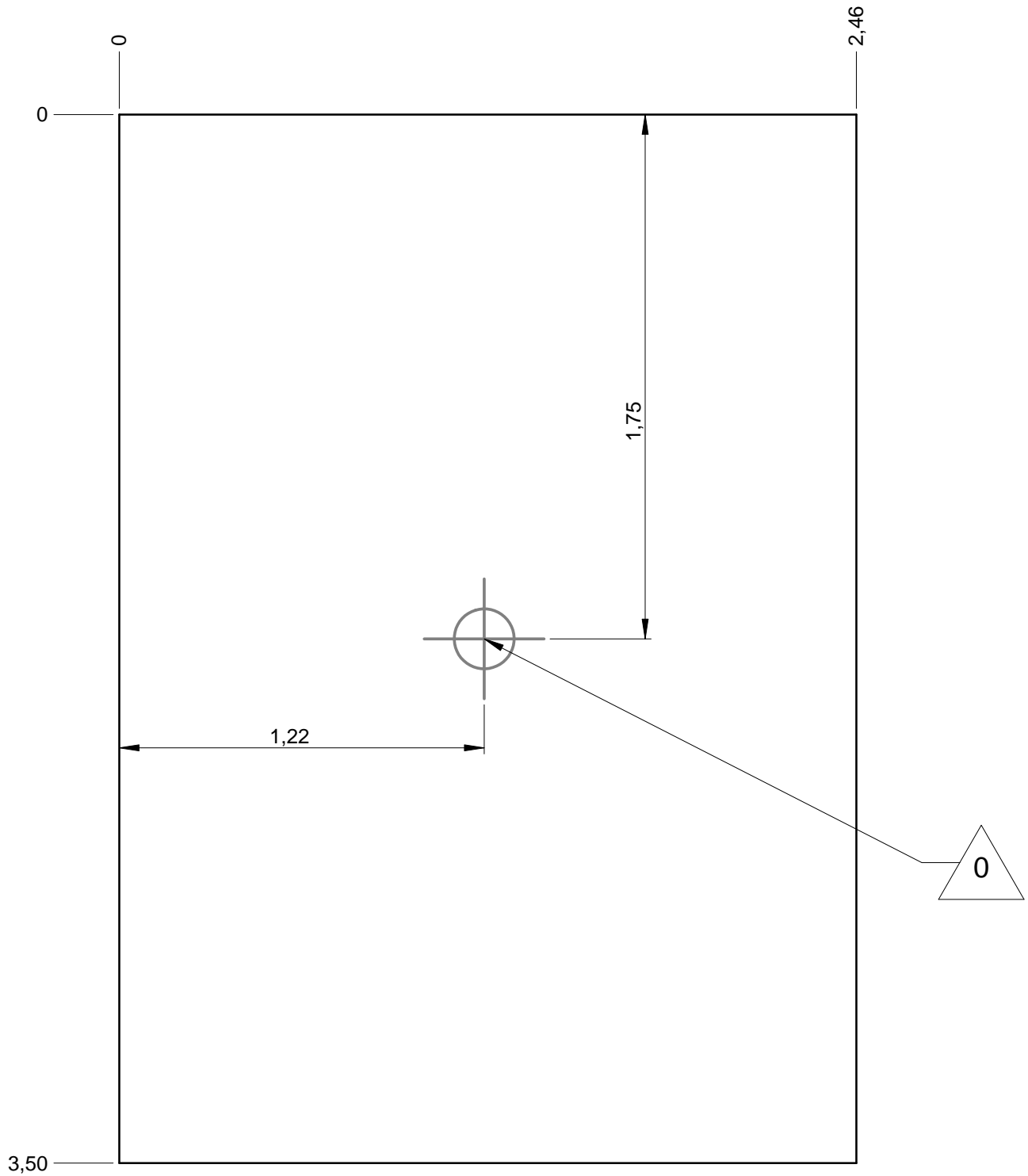

J....A

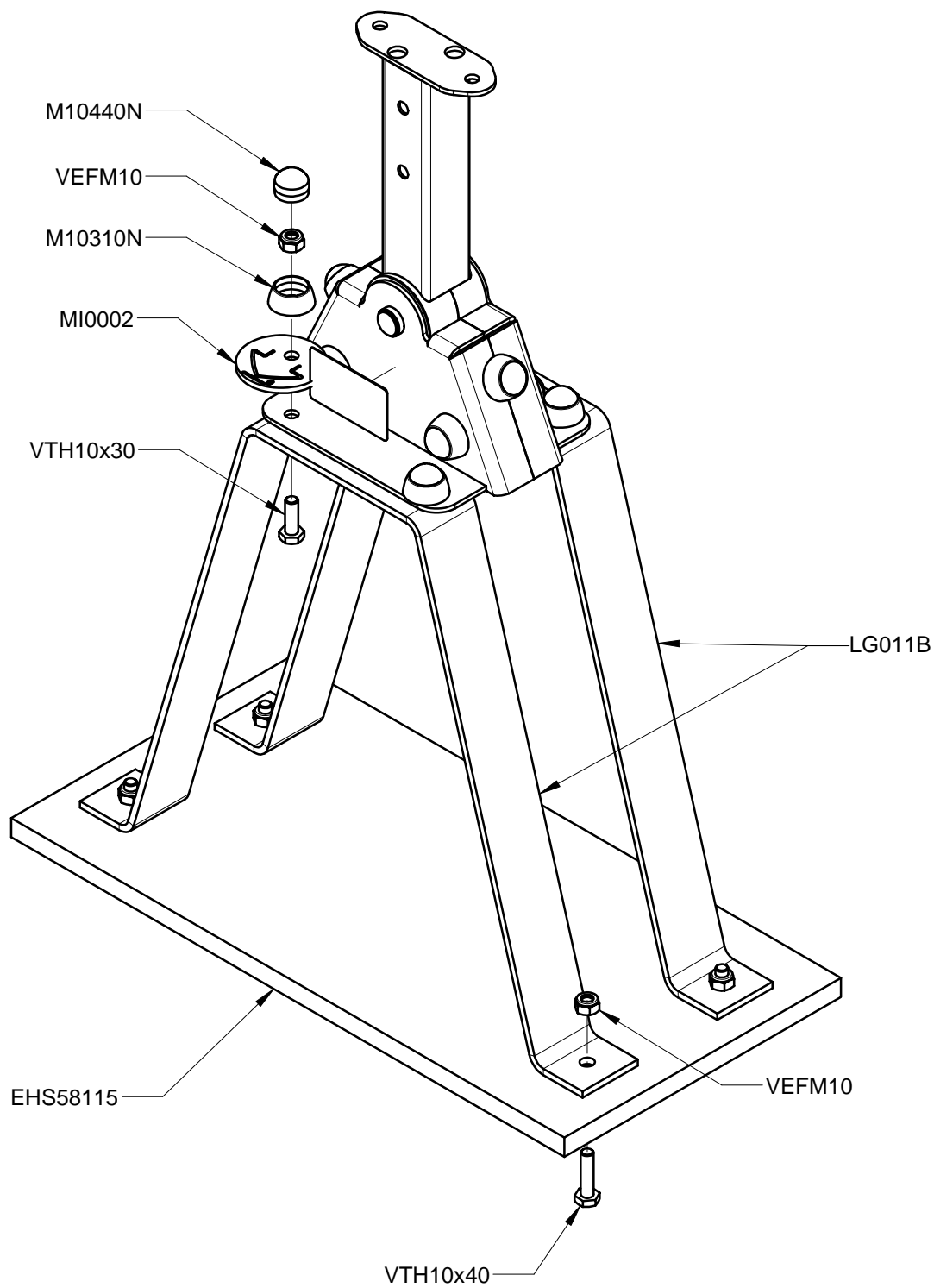

J.....A

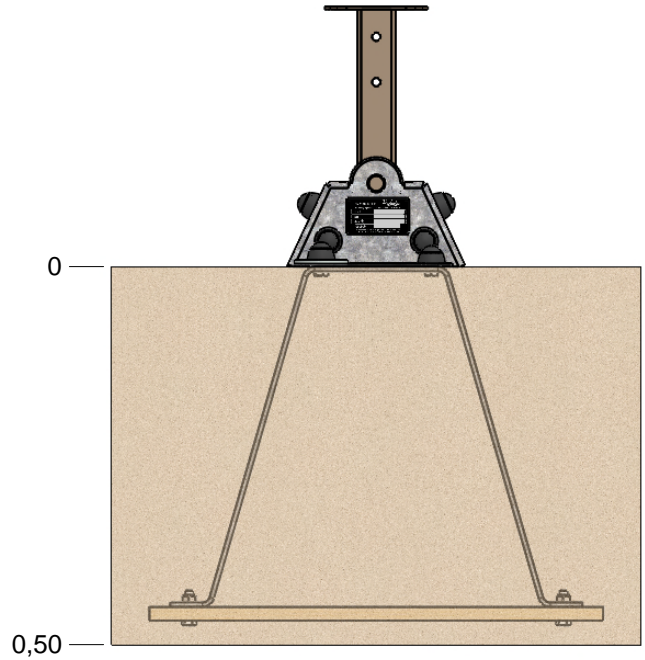
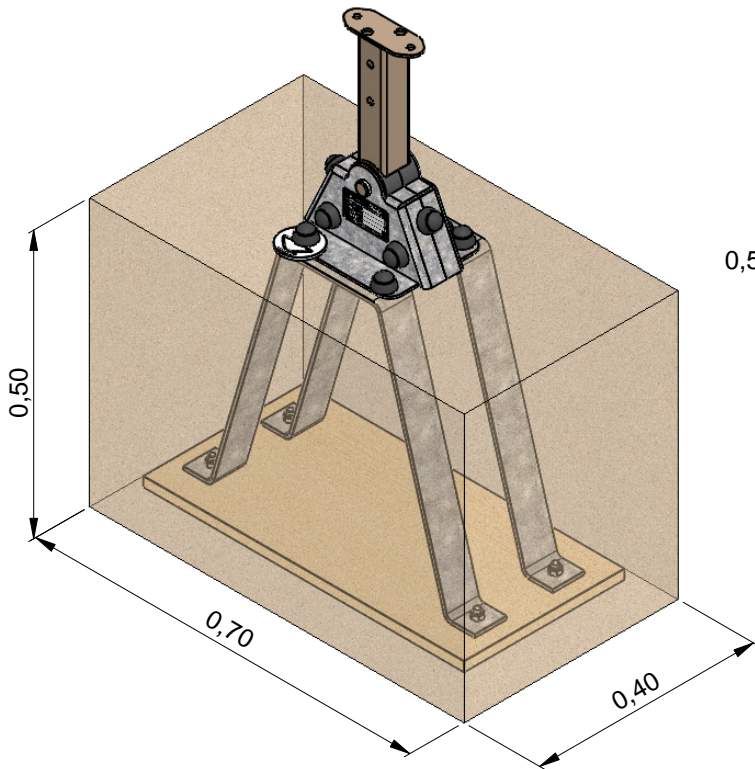

 $>1500 \text{ Kgs/m}^3$

 $<1500 \text{ Kgs/m}^3$

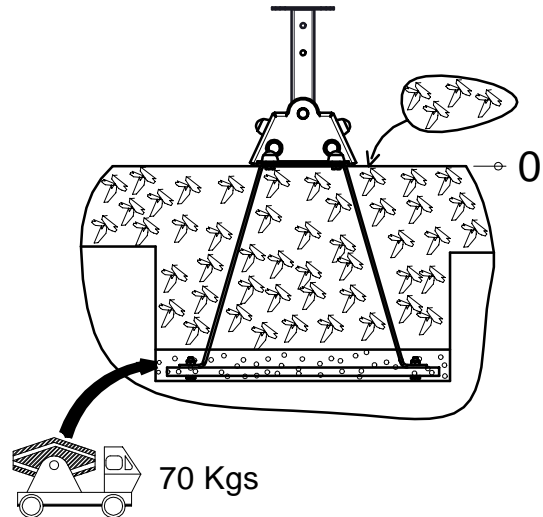
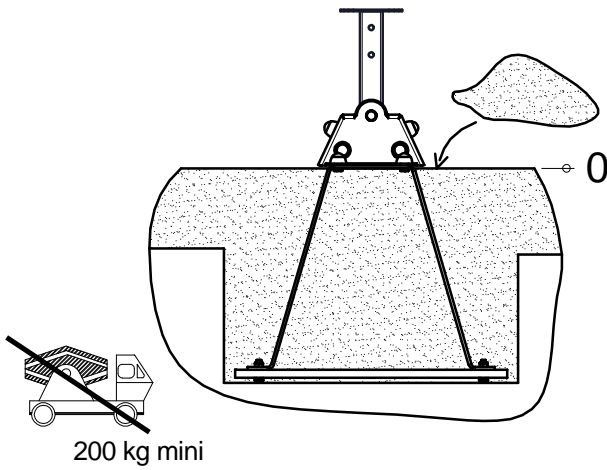

Implantation
Footing plan
Implantación
Fundamentplan
Funderingstekening

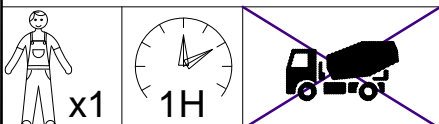
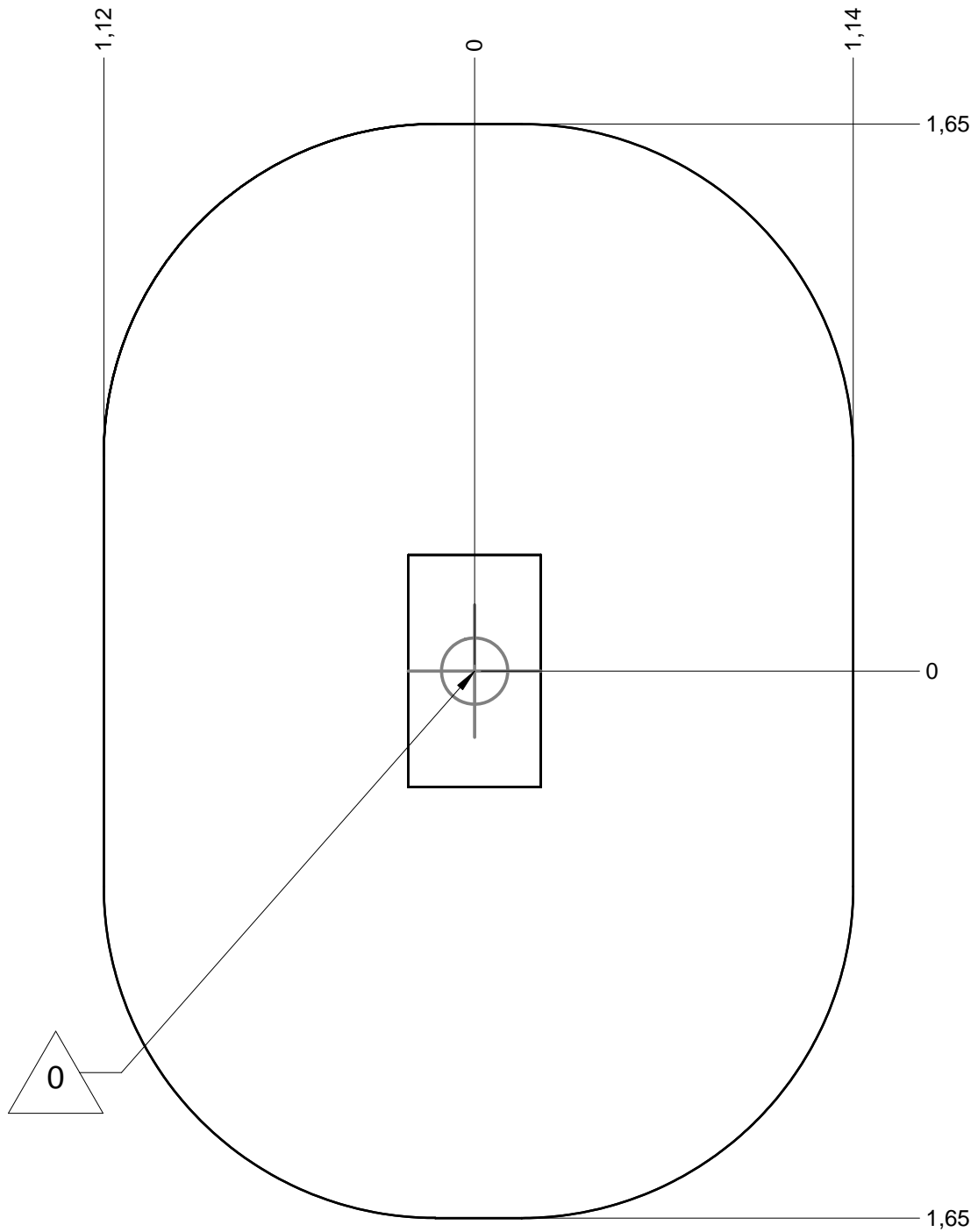

J....B

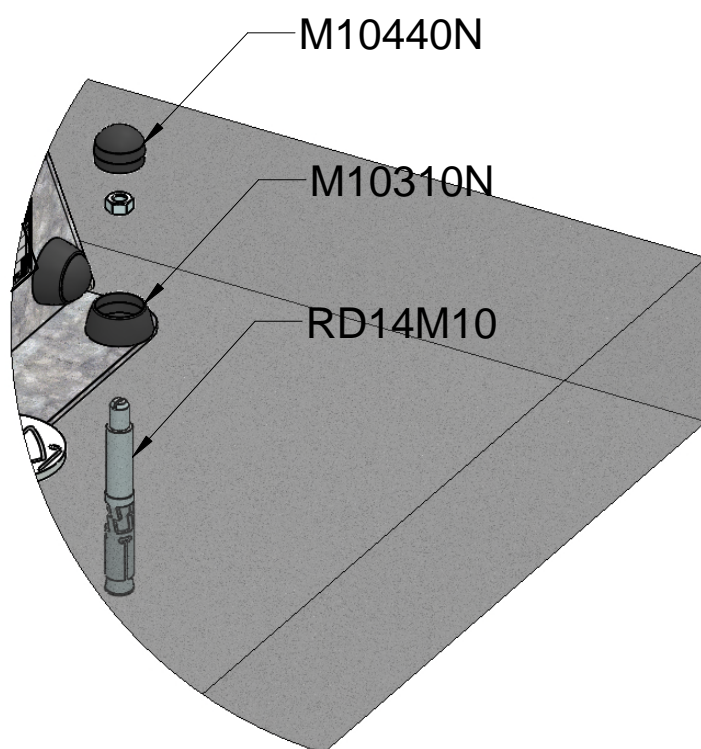
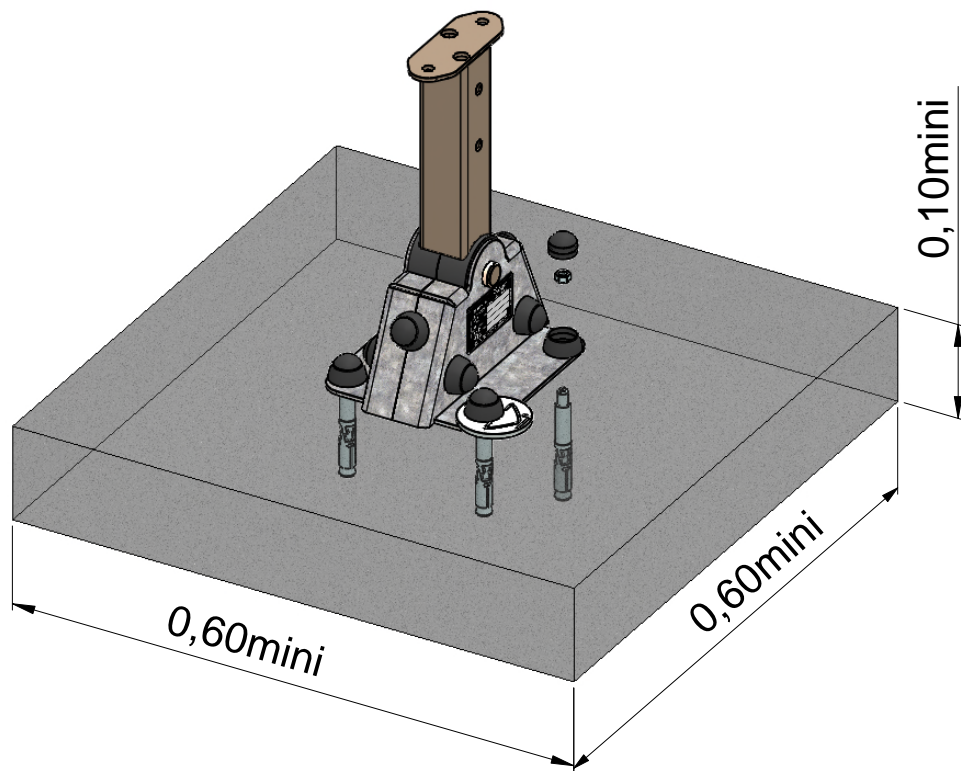

Implantation
Footing plan
Implantación
Fundamentplan
Funderingstekening

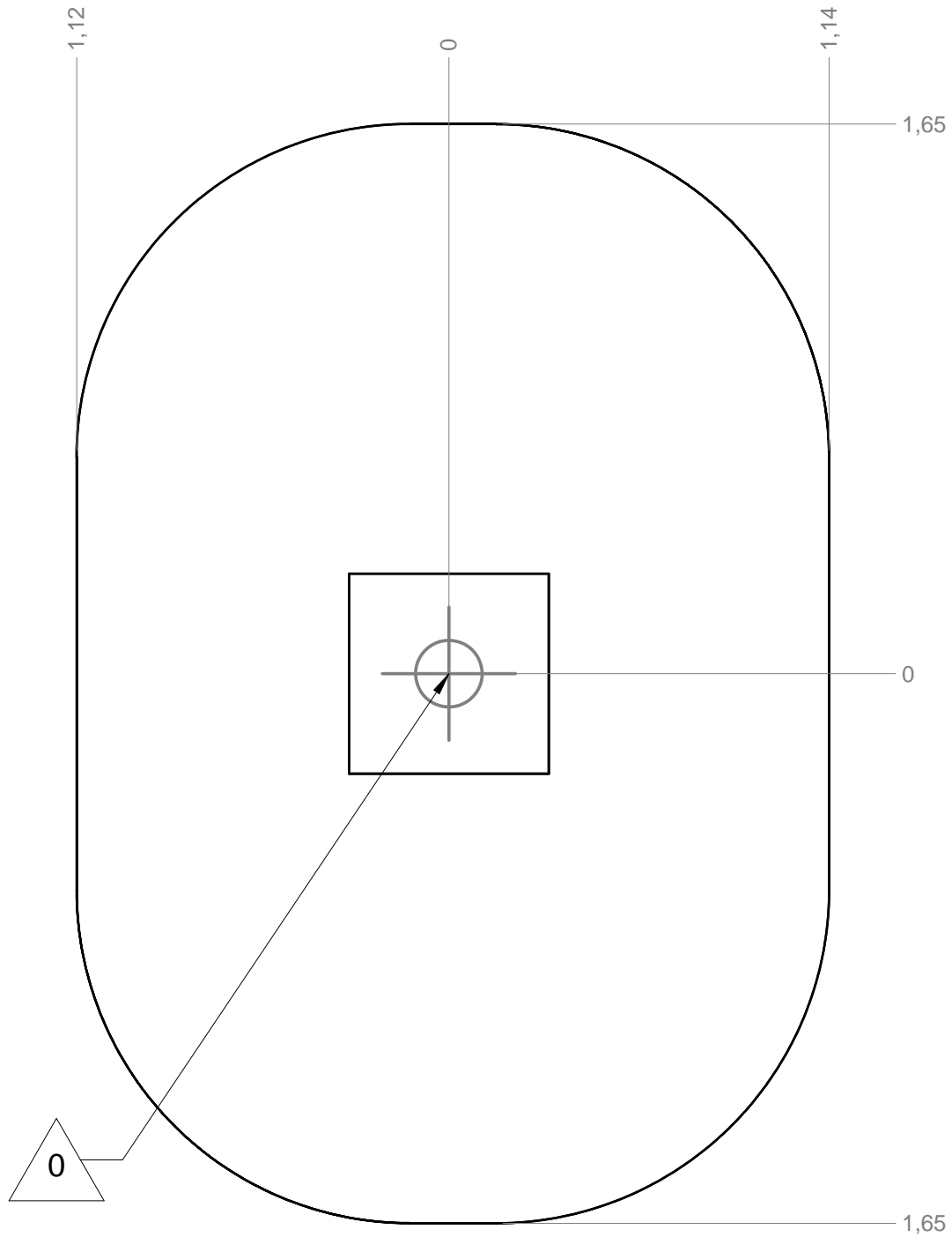

x1



1H

RD14M10



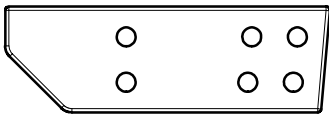
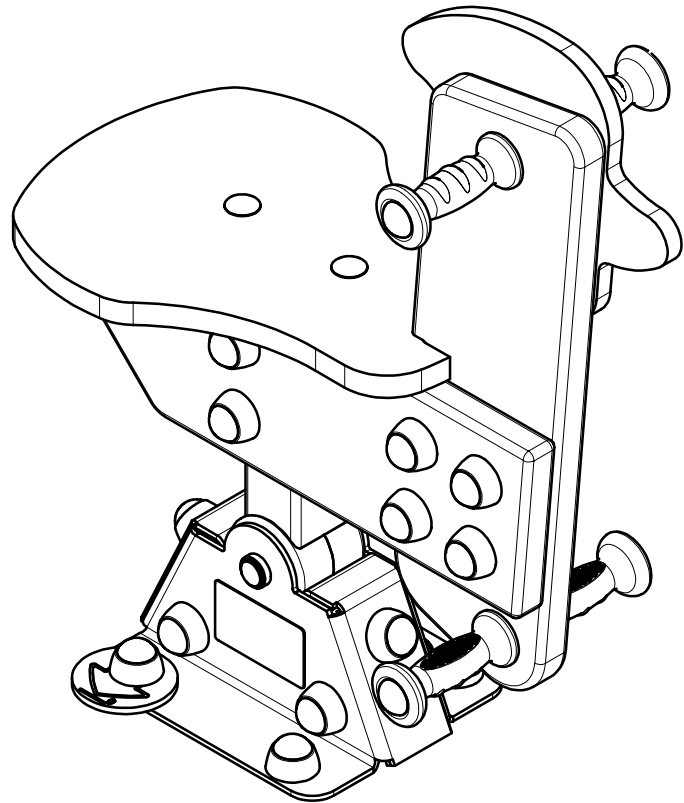

DM58104

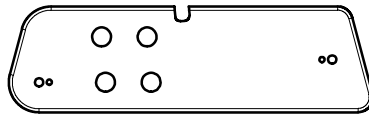

DM58105

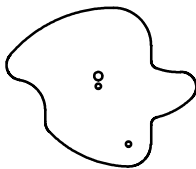

ET58107J

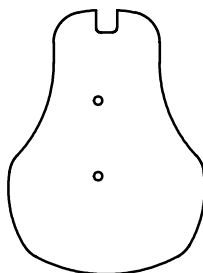

F58113

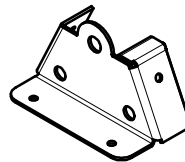

LG58108

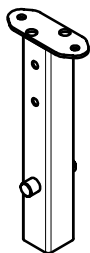

LGP58109

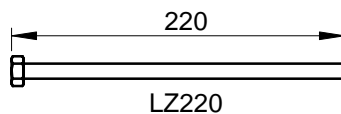

LZ220

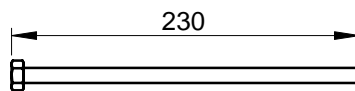

LZ230

DM58104	1
DM58105	1
F58113	1
L58112	2
LA000	1
LG58108	2
LG58111	2
LGP58109	1
LZ220	1
LZ230	1
M10310N	25
M10440N	29
M58110	2
MI0002	1
MI820N	4
MU2614	6
MU3908	4
R2504	2
VBT6x30	1
VEFM10	15
VR10x22	4
VTH10x70	4
VTH10x90	2
VTH10x100	2
VTRCC10x40	2
RD14M10	4
ET58107J	1

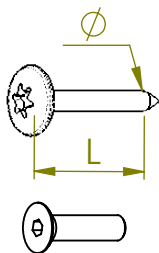

VBT 6 x 30
 \varnothing \uparrow L (mm)

VFHC



VEC M10
 \varnothing



VEF



VEB

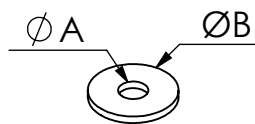

VR6x18
 $\varnothing A$ $\varnothing B$

VTHA

1000 - 1800 RPM
 Vitesse de rotation
 Rotation speed

< 14 N.m
 Couple de rupture
 Breakage torque

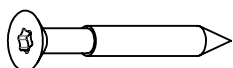

VWT

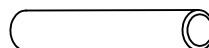

VGC

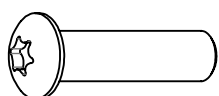

VCBHC

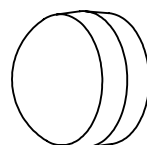

M10 440N

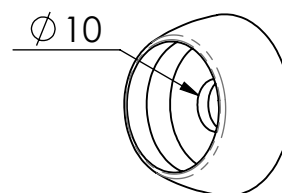

M10 310 N

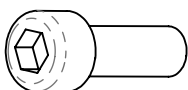

VBTR

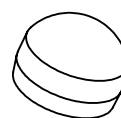

M8 440N

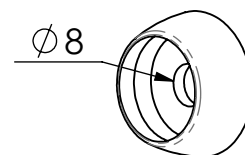

M8 310N

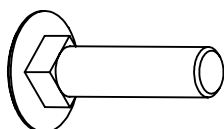

VTRCC

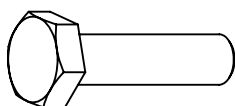

VTH

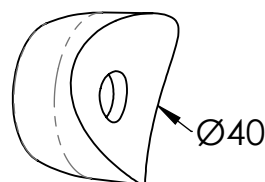

MI2503

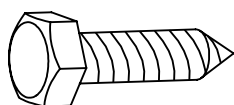

VTF

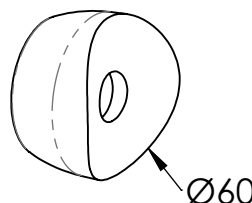

MI2701

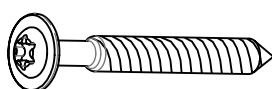

VBT

REF	Désignation	Matière	Longueur
MU1012	LG 425	PVC rigide	425
MU1050	LG 401	PVC rigide	401
MU2355	LG 594	PVC rigide	594
MU2507	LG 110	PVC rigide	110
MU2603	LG 40	PVC rigide	40
MU2614	LG 24	PVC rigide	24
MU277	LG 150	PVC rigide	150
MU3502	LG 148	PVC rigide	148
MU3508	LG 55	PVC rigide	55
MU3801	LG 90	PVC rigide	90
MU3903	LG 114	PVC rigide	114
MU3906	LG 250	PVC rigide	250
MU3908	LG 30	PVC rigide	30
MU3909	LG 10	PVC rigide	10
MU440	LG 100	PVC rigide	100
MU4700	LG 15	PVC rigide	15
MU5012	LG 125	PVC rigide	125
MU502	LG 185	PVC rigide	185
MU5600	LG 87	PVC rigide	87
MU720	LG 720	PVC rigide	720
MU9000	LG 555	PVC rigide	555
MU9001	LG 36	PVC rigide	36
MU9002	LG 42	PVC rigide	42
MU9004	LG 405	PVC rigide	405
MU901	LG 70	PVC rigide	70
MU902	LG 226	PVC rigide	226
MU903	LG 296	PVC rigide	296
MU904	LG 21,5	PVC rigide	21,5
MU905	LG 330	PVC rigide	330
MU910	LG 60	PVC rigide	60
MU930	LG 80	PVC rigide	80

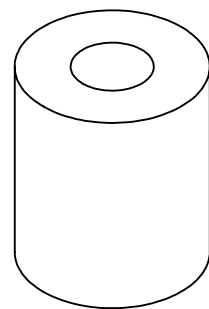
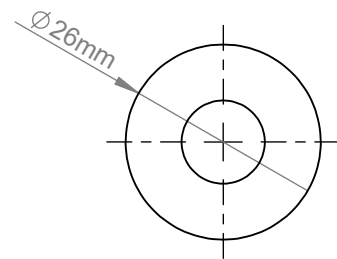
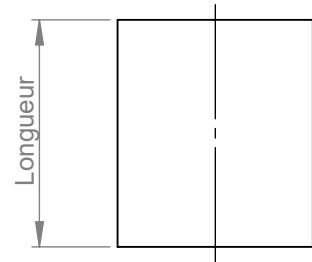

1

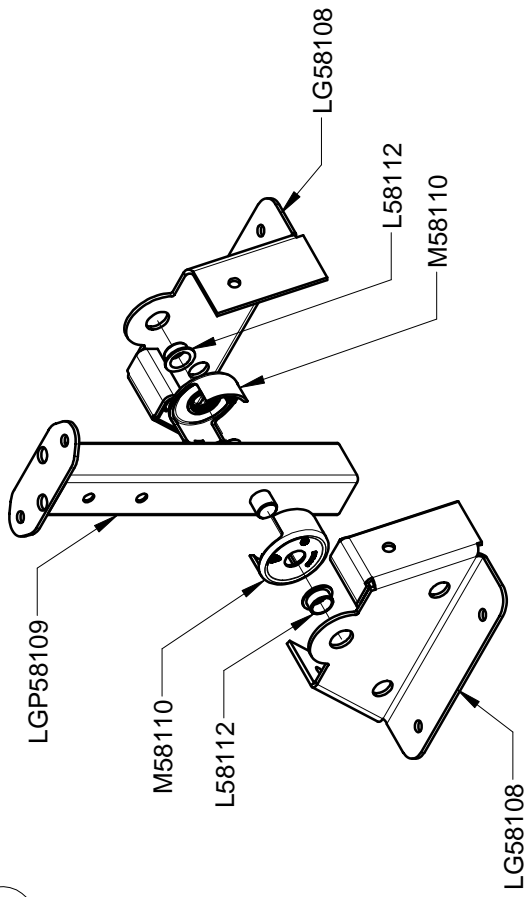

3

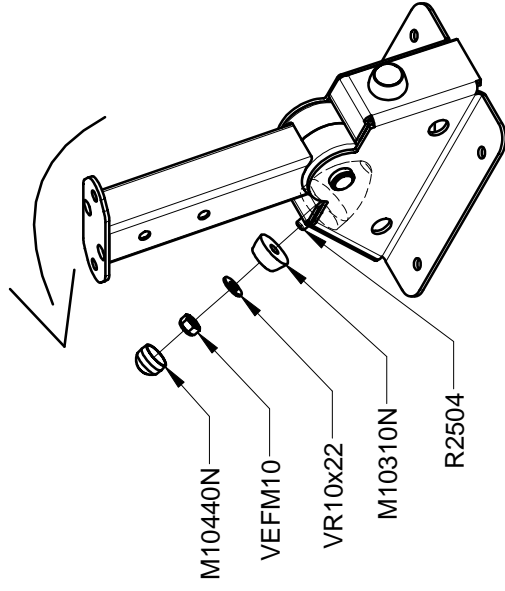

2

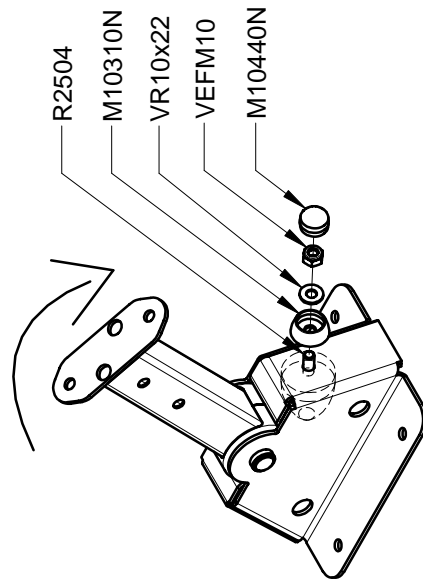

4

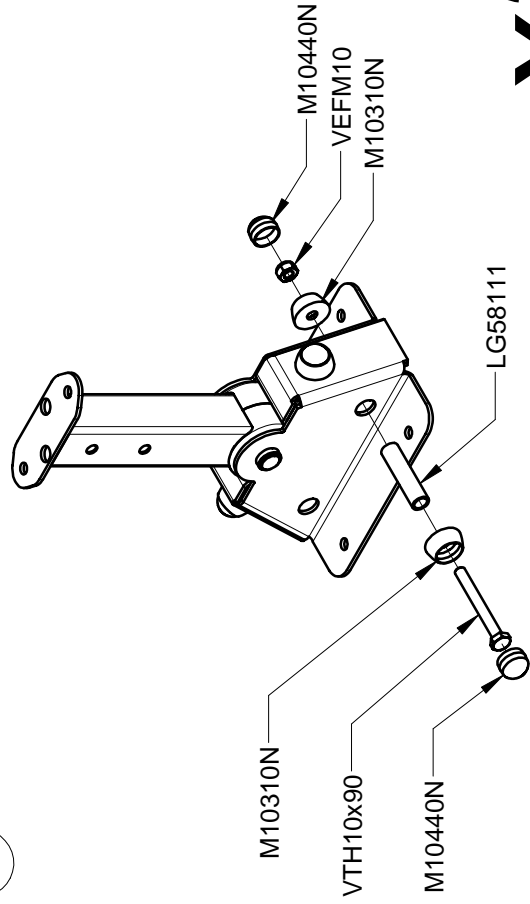

X2

5

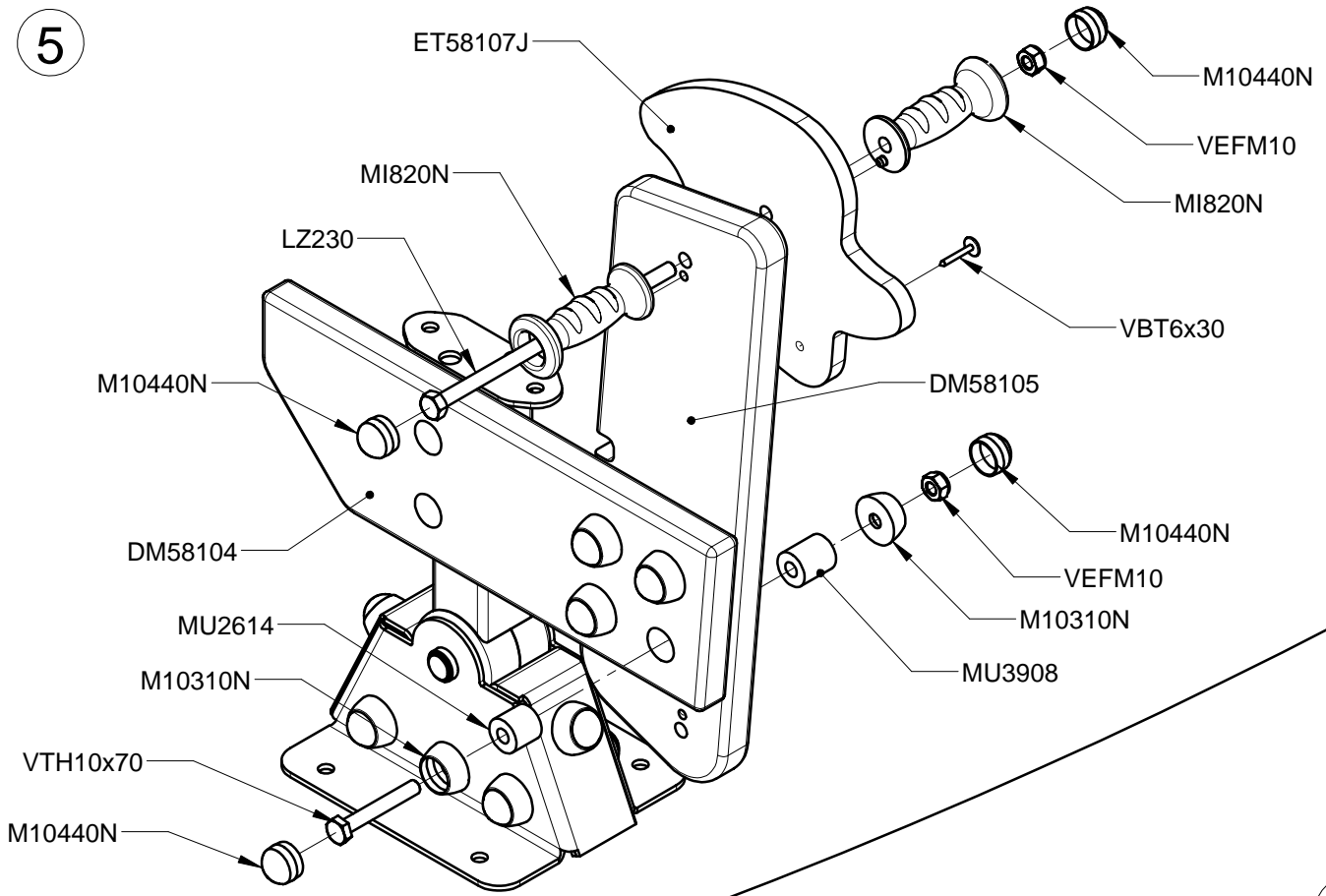

6

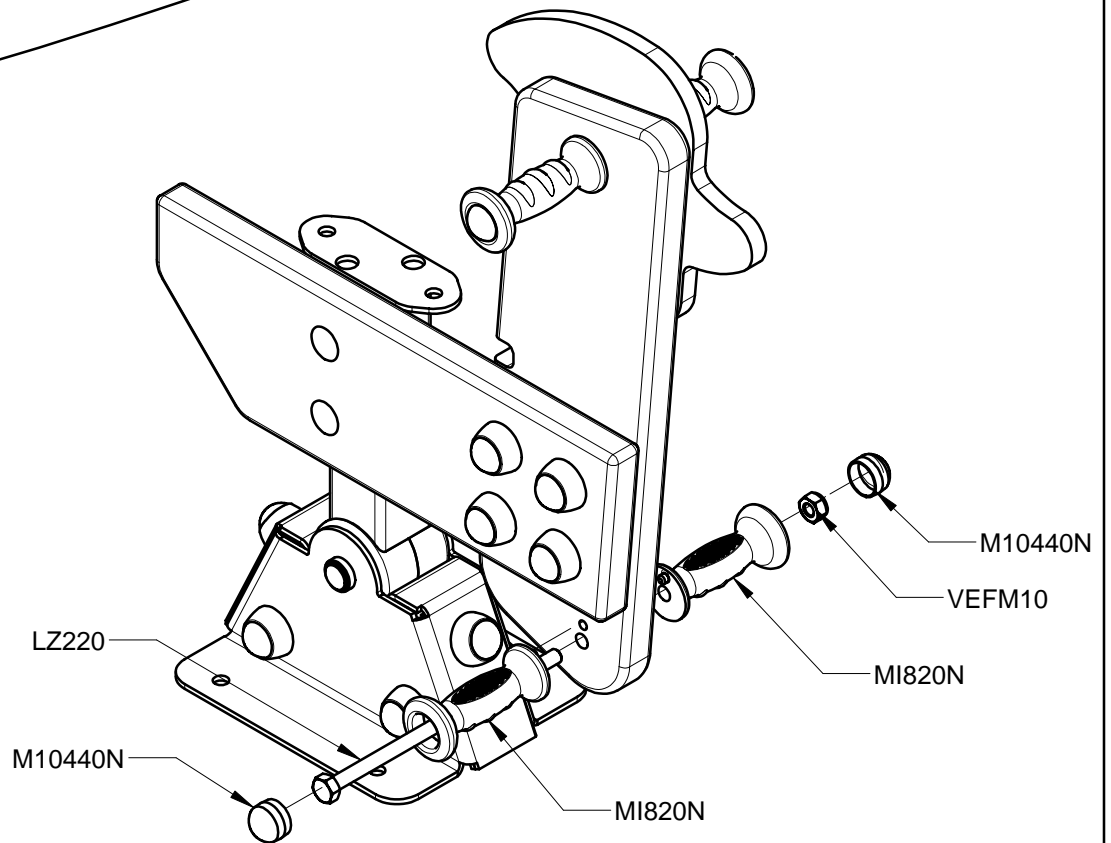

7

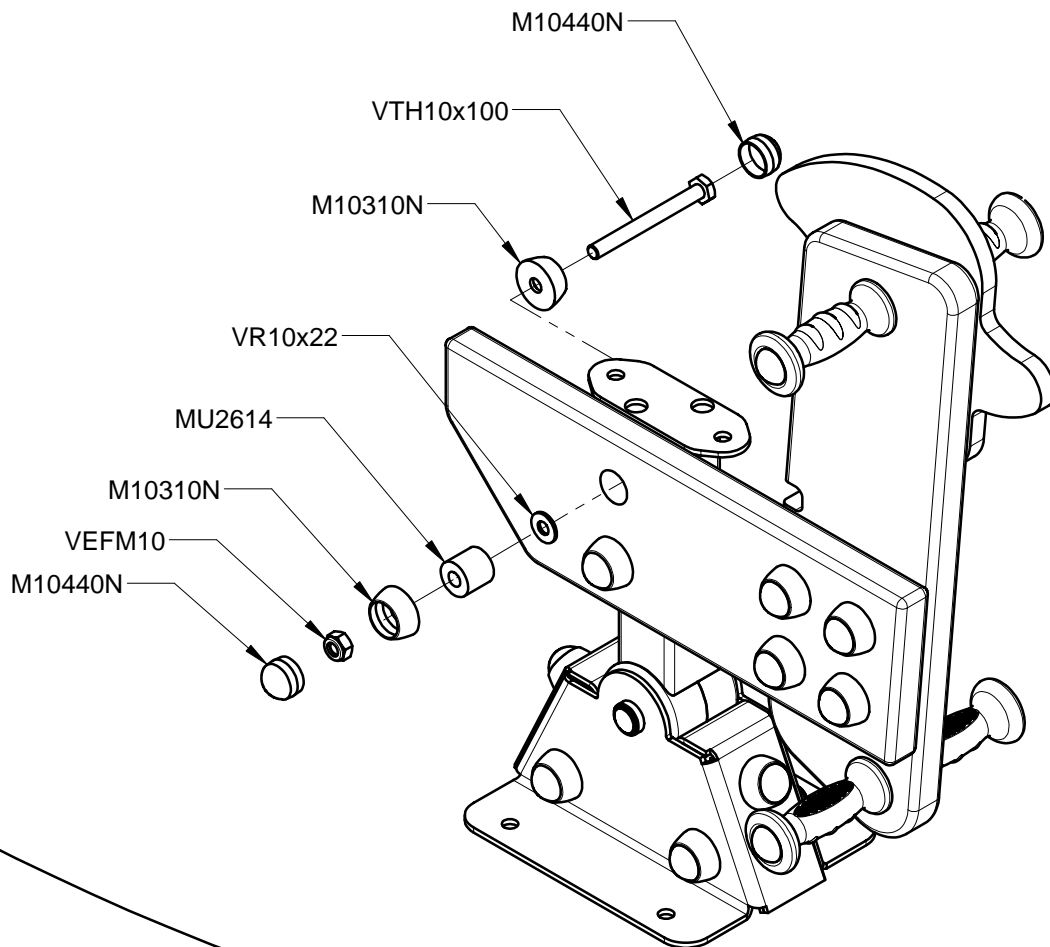

8

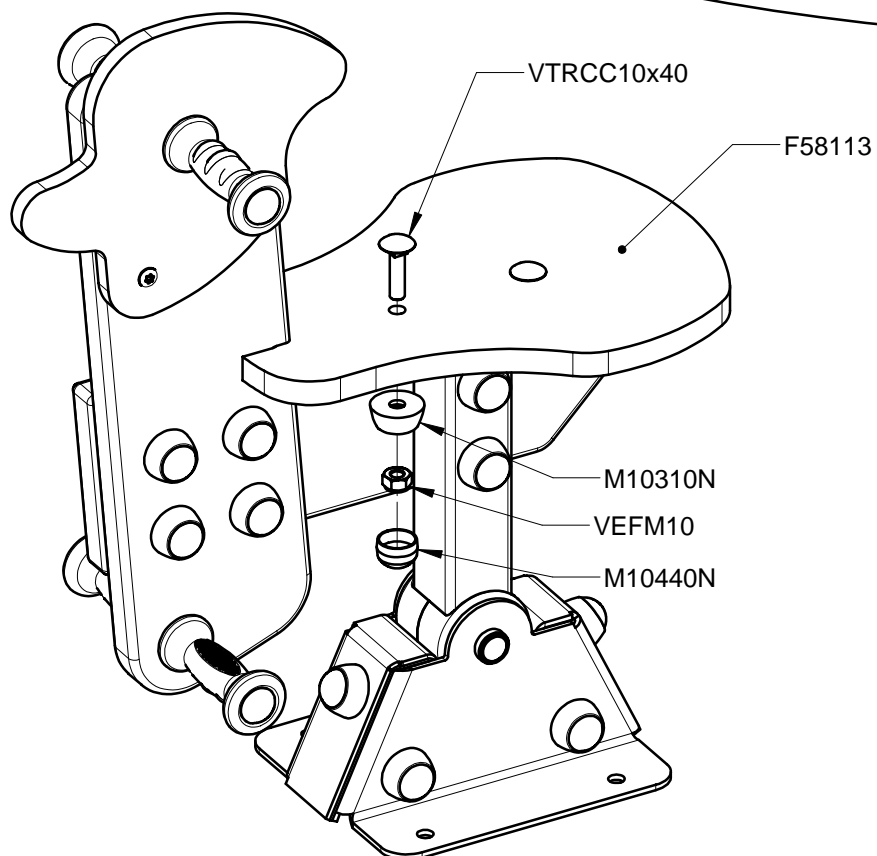

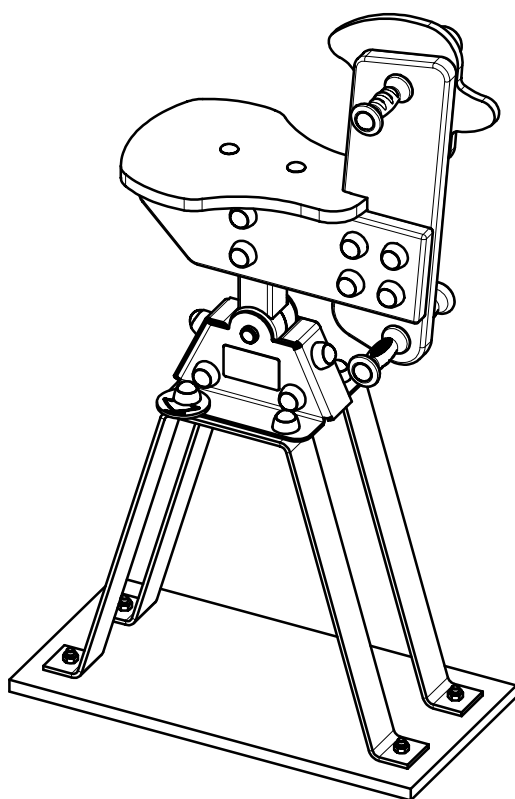

Réf	Qté
DM58104	1
DM58105	1
EHS58115	1
F58113	1
L58112	2
LA000	1
LG011B	2
LG58108	2
LG58111	2
LGP58109	1
LZ220	1
LZ230	1
M10310N	24
M10440N	28
M58110	2
MI0002	1
MI820N	4
MU2614	6
MU3908	4
R2504	2
VBT6x30	1
VEFM10	22
VR10x22	4
VTH10x30	4
VTH10x40	4
VTH10x70	4
VTH10x90	2
VTH10x100	2
VTRCC10x40	2
ET58107J	1